

Lit. zmian	Data	Podpis	Nr karty. zm.

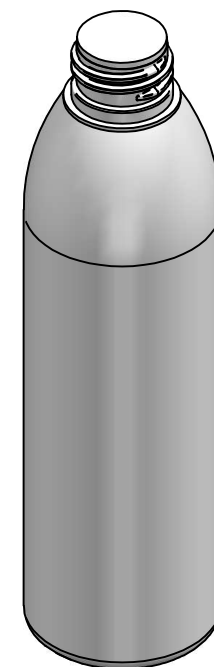
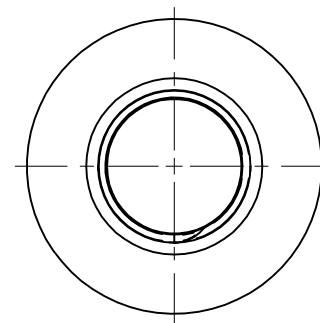
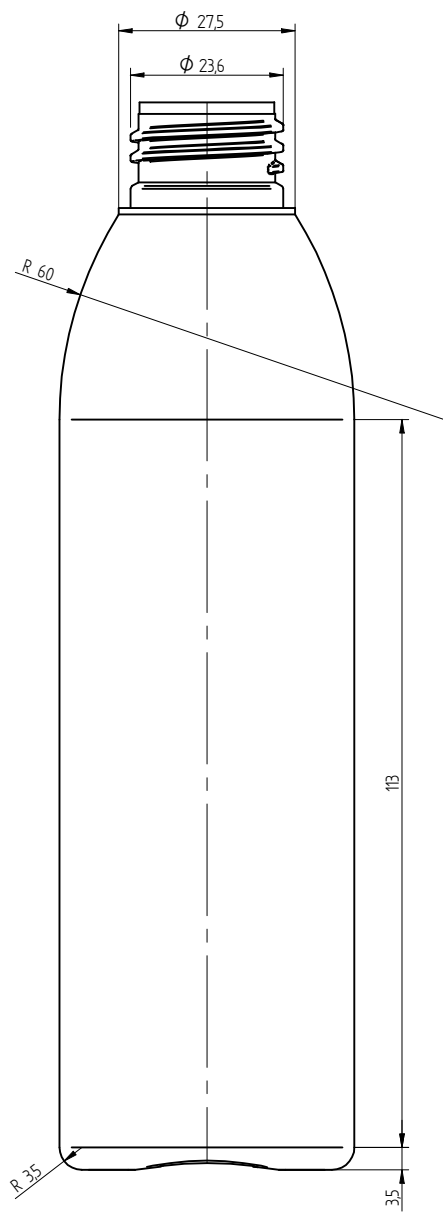
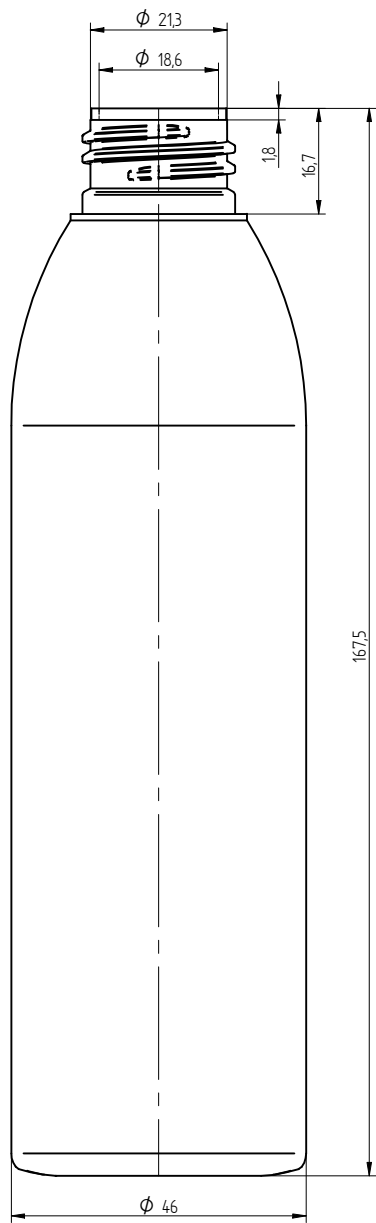

Material	Oznaczenie	HDPE		Waga	Pojemność
	Nr normy			17±1,5g	220±7ml
Konstr.	Zięcina K.	15.07.2017		Nazwa wyrobu	
Sprawdził	Kacprzyk M.	15.07.2017		Butelka KLARA G24 200ML	
Podz.	Format	PLASTAN S.J.			Nr rysunku
1,2:1	A3				G-35/01